

Gorge Road @ Millgrove Street

Tuesday, April 02, 2019



The data presented here is for information purposes only and should not be considered authoritative for construction, geotechnical, engineering, navigational, legal, or other site-specific uses. The information shared is owned by the Transportation Division of the Engineering Department at the District of Saanich. Accuracy is not guaranteed.

Major Route: Gorge Road
Minor Route: Millgrove Street
Municipality: Saanich
Filename: Gorge Rd @ Millgrove St-Apr 2, 2019.xlsx
Location #: TIN001042
Count ID: 2019013
Date: April 2, 2019
Day-of-week: Tuesday

East/West Route: Millgrove Street
Intersection Type: 3-leg east approach
Signalized?: Yes
Weather: Overcast and dry

Vehicle Classifications: Vehicles and Peds
 Bikes

This data is for Vehicles and Peds

Shift	Start	End	Duration
AM	7:30	9:30	2.00
MD			
PM	15:30	18:30	3.00
Total	7:30	18:30	5.00

Notes: 24-hour clock used for reporting (15-minute increments)
 North Approach - southbound vehicles approaching intersection from the north
 15x4 - 15 min volume (from maximum 15 minute period of movement/approach in peak hour period [*]) x 4
 Pedestrians - N indicates pedestrians crossing north approach (east/west)

Comments:

Survey Data
Vehicles and Peds

Gorge Road @ Millgrove Street
Tuesday, April 2, 2019

Time Period Begins	Gorge Rd NORTH Approach				Gorge Rd SOUTH Approach				WEST Approach				Millgrove St EAST Approach				Total Volume		Ped DL	Crosswalks			
	Left	Thru	Right	Total	Left	Thru	Right	Total	Left	Thru	Right	Total	Left	Thru	Right	Total	15-min	Hour		N	S	W	E
7:30	0	191		191		128	1	129					2		1	3	323		*	1	0		0
7:45	1	217		218		118	0	118					0		2	2	338		*	6	0		0
8:00	0	208		208		105	1	106					1		1	2	316		*	4	0		0
8:15	2	240		242		133	1	134					1		3	4	380	1357	+	3	0		4
8:30	3	187		190		128	0	128					1		3	4	322	1356		3	1		5
8:45	2	187		189		117	0	117					1		2	3	309	1327		0	1		0
9:00	1	174		175		106	1	107					0		2	2	284	1295		0	0		4
9:15	0	156		156		129	1	130					1		1	2	288	1203		4	0		2
n/a																							
n/a																							
n/a																							
n/a																							
n/a																							
n/a																							
n/a																							
n/a																							
n/a																							
n/a																							
n/a																							
n/a																							
n/a																							
Total	9	1560		1569		964	5	969					7		15	22	2560			21	2		15

n/a																							
n/a																							
n/a																							
n/a																							
n/a																							
n/a																							
n/a																							
n/a																							
n/a																							
n/a																							
n/a																							
n/a																							
n/a																							
n/a																							
n/a																							
n/a																							
Total																							

15:30	0	127		127		253	4	257					2		3	5	389			3	2		1
15:45	0	118		118		274	1	275					1		2	3	396			1	1		4
16:00	0	136		136		290	1	291					0		1	1	428			2	1		3
16:15	3	141		144		269	0	269					0		2	2	415	1628		2	0		3
16:30	7	133		140		315	4	319					3		2	5	464	1703	*	5	0		3
16:45	2	158		160		324	2	326					0		0	0	486	1793	+	6	2		3
17:00	1	108		109		317	6	323					0		5	5	437	1802	*	3	0		4
17:15	3	141		144		291	5	296					1		2	3	443	1830	*	6	1		6
17:30	1	112		113		258	2	260					0		1	1	374	1740		5	0		3
17:45	0	111		111		229	0	229					0		2	2	342	1596		1	1		3
18:00	0	113		113		189	0	189					3		3	6	308	1467		4	0		2
18:15	0	100		100		163	0	163					0		4	4	267	1291		2	0		3
n/a																							
n/a																							
n/a																							
n/a																							
n/a																							
n/a																							
n/a																							
n/a																							
n/a																							
Total	17	1498		1515		3172	25	3197					10		27	37	4749			40	8		38

AM Peak Period
Vehicles and Peds

Gorge Road @ Millgrove Street
Tuesday, April 2, 2019

Time Period Begins	Gorge Rd NORTH Approach				Gorge Rd SOUTH Approach				WEST Approach				EAST Approach				Total Volume		Ped %	Crosswalks				Conflict	
	Left	Thru	Right	Total	Left	Thru	Right	Total	Left	Thru	Right	Total	Left	Thru	Right	Total	15-min	Hour		N	S	W	E	15 min	Hr
7:30	0	191		191	128	1	129					2		1	3	323	*	1	0		0	193			
7:45	1	217		218	118	0	118					0		2	2	338	*	6	0		0	219			
8:00	0	208		208	105	1	106					1		1	2	316	*	4	0		0	209			
8:15	2	240		242	133	1	134					1		3	4	380	1357+	3	0		4	243	864		
8:30	3	187		190	128	0	128					1		3	4	322	1356	3	1		5	190	861		
8:45	2	187		189	117	0	117					1		2	3	309	1327	0	1		0	189	831		
9:00	1	174		175	106	1	107					0		2	2	284	1295	0	0		4	176	798		
9:15	0	156		156	129	1	130					1		1	2	288	1203	4	0		2	157	712		
n/a																									
n/a																									
n/a																									
n/a																									
n/a																									
n/a																									
n/a																									
n/a																									
n/a																									
n/a																									
n/a																									
n/a																									
n/a																									
n/a																									

Total	9	1560		1569	964	5	969					7	15	22	2560			21	2		15	1575
Avg Hr	5	780		785	482	3	485					4	8	11	1280			11	1		8	

Peak hour of the intersection

Pk Hr	3	856		859	484	3	487					4	7	11	1357*			14	0		4	863
15x4	8	960		968	532	4	536					8	12	16	1520+			24	0		16	972
PHF	0.38	0.89		0.89	0.91	0.75	0.91					0.50	0.58	0.69	0.89			0.58	n/a		0.25	0.89

Peak hour of conflicting volumes for the intersection

Pk Hr	3	856		859	484	3	487					4	7	11	1357*			14	0		4	863
15x4	8	960		968	532	4	536					8	12	16	1520+			24	0		16	972
PHF	0.38	0.89		0.89	0.91	0.75	0.91					0.50	0.58	0.69	0.89			0.58	n/a		0.25	0.89

** Calculated peak hour occurs during the first or last hour of shift and therefore may be invalid. **

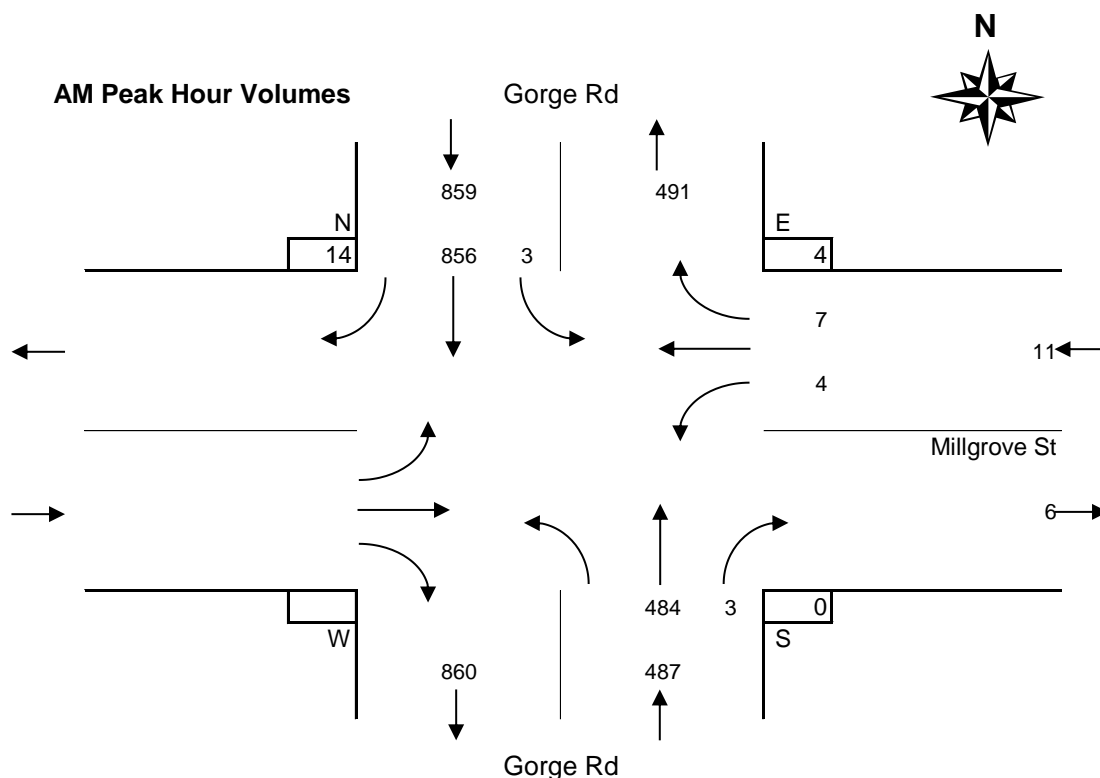

Time Period Begins	Gorge Rd NORTH Approach				Gorge Rd SOUTH Approach				WEST Approach				EAST Approach				Total Volume		Ped C/L	Crosswalks				Conflict	
	Left	Thru	Right	Total	Left	Thru	Right	Total	Left	Thru	Right	Total	Left	Thru	Right	Total	15-min	Hour		N	S	W	E	15 min	Hr
n/a																									
n/a																									
n/a																									
n/a																									
n/a																									
n/a																									
n/a																									
n/a																									
n/a																									
n/a																									
n/a																									
n/a																									
n/a																									
n/a																									
n/a																									
n/a																									
n/a																									
n/a																									
n/a																									
n/a																									
n/a																									

Total																									
Avg Hr																									

Peak hour of the intersection

Pk Hr																									
15x4																									
PHF																									

Peak hour of conflicting volumes for the intersection

Pk Hr																									
15x4																									
PHF																									

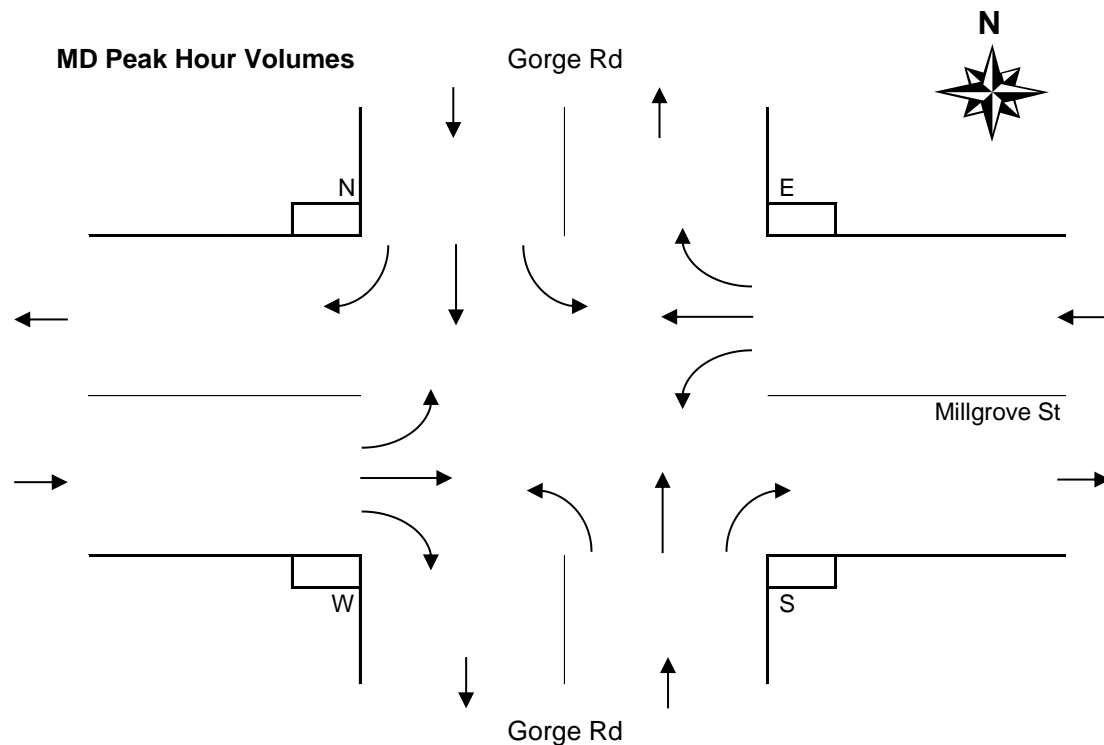

Time Period Begins	Gorge Rd NORTH Approach				Gorge Rd SOUTH Approach				WEST Approach				EAST Approach				Total Volume		Ped	Crosswalks				Conflict	
	Left	Thru	Right	Total	Left	Thru	Right	Total	Left	Thru	Right	Total	Left	Thru	Right	Total	15-min	Hour		N	S	W	E	15 min	Hr
	15:30	0	127		127	253	4		257					2		3	5	389			3	2		1	260
15:45	0	118		118	274	1		275					1		2	3	396		1	1		4	277		
16:00	0	136		136	290	1		291					0		1	1	428		2	1		3	292		
16:15	3	141		144	269	0		269					0		2	2	415	1628	2	0		3	274	1103	
16:30	7	133		140	315	4		319					3		2	5	464	1703	5	0		3	329	1172	
16:45	2	158		160	324	2		326					0		0	0	486	1793	6	2		3	328	1223	
17:00	1	108		109	317	6		323					0		5	5	437	1802	3	0		4	329	1260	
17:15	3	141		144	291	5		296					1		2	3	443	1830	6	1		6	301	1287	
17:30	1	112		113	258	2		260					0		1	1	374	1740	5	0		3	262	1220	
17:45	0	111		111	229	0		229					0		2	2	342	1596	1	1		3	231	1123	
18:00	0	113		113	189	0		189					3		3	6	308	1467	4	0		2	192	986	
18:15	0	100		100	163	0		163					0		4	4	267	1291	2	0		3	167	852	
n/a																									
n/a																									
n/a																									
n/a																									
n/a																									
n/a																									
n/a																									
n/a																									
n/a																									
n/a																									
n/a																									
n/a																									

Total	17	1498		1515	3172	25	3197						10		27	37	4749					40	8		38	3241
Avg Hr	6	499		505	1057	8	1066						3		9	12	1583					13	3		13	

Peak hour of the intersection

Pk Hr	13	540		553	1247	17	1264						4		9	13	1830					20	3		16	1286
15x4	28	632		640	1296	24	1304						12		20	20	1944					24	8		24	1368
PHF	0.46	0.85		0.86	0.96	0.71	0.97						0.33		0.45	0.65	0.94					0.83	0.38		0.67	0.94

Peak hour of conflicting volumes for the intersection

Pk Hr	13	540		553	1247	17	1264						4		9	13	1830					20	3		16	1286
15x4	28	632		640	1296	24	1304						12		20	20	1944					24	8		24	1368
PHF	0.46	0.85		0.86	0.96	0.71	0.97						0.33		0.45	0.65	0.94					0.83	0.38		0.67	0.94

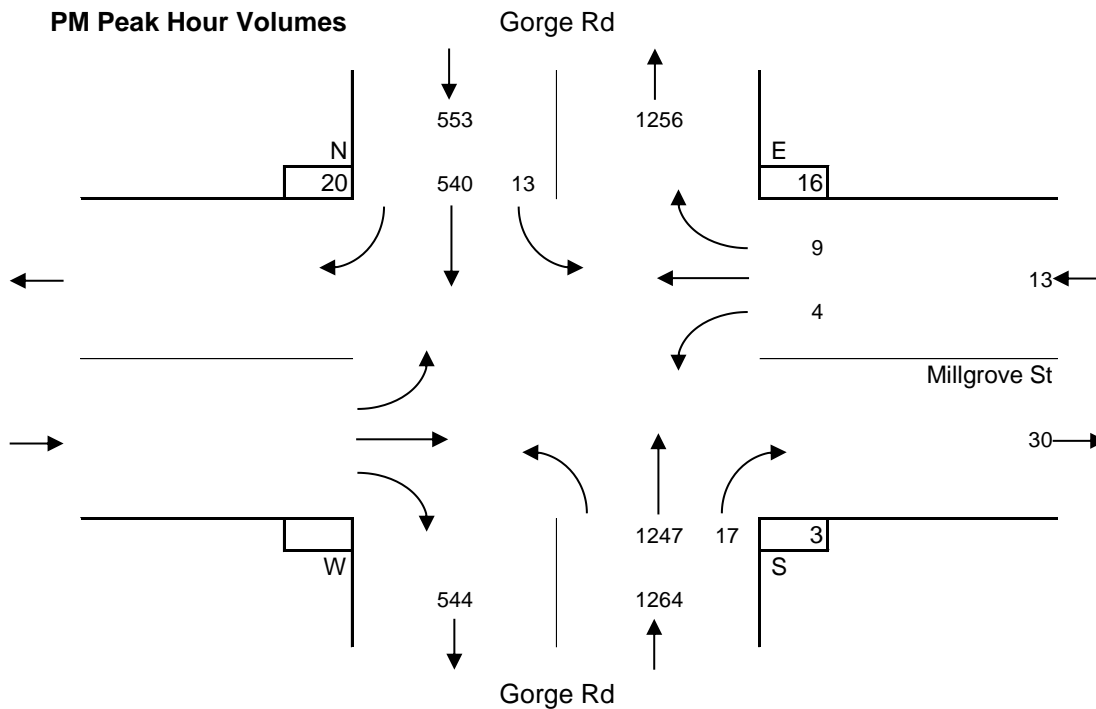

Entire Survey Period

5 Hours

	Gorge Rd				Gorge Rd				WEST Approach				Millgrove St				Total Volume	Crosswalks			
	NORTH Approach				SOUTH Approach								EAST Approach					N S W E			
	Left	Thru	Right	Total	Left	Thru	Right	Total	Left	Thru	Right	Total	Left	Thru	Right	Total		N	S	W	E
Total	26	3058		3084		4136	30	4166					17		42	59	7309	61	10		53
Avg Hr	5	612		617		827	6	833					3		8	12	1462	12	2		11

AM Peak Period

2 Hours

	Gorge Rd				Gorge Rd				WEST Approach				Millgrove St				Total Volume	Crosswalks			
	NORTH Approach				SOUTH Approach								EAST Approach					N S W E			
	Left	Thru	Right	Total	Left	Thru	Right	Total	Left	Thru	Right	Total	Left	Thru	Right	Total		N	S	W	E
Totals	9	1560		1569		964	5	969					7		15	22	2560	21	2		15
Avg Hr	5	780		785		482	3	485					4		8	11	1280	11	1		8

MD Peak Period

Hours

	Gorge Rd				Gorge Rd				WEST Approach				Millgrove St				Total Volume	Crosswalks			
	NORTH Approach				SOUTH Approach								EAST Approach					N S W E			
	Left	Thru	Right	Total	Left	Thru	Right	Total	Left	Thru	Right	Total	Left	Thru	Right	Total		N	S	W	E
Totals																					
Total																					
Avg Hr																					

PM Peak Period

3 Hours

	Gorge Rd				Gorge Rd				WEST Approach				Millgrove St				Total Volume	Crosswalks			
	NORTH Approach				SOUTH Approach								EAST Approach					N S W E			
	Left	Thru	Right	Total	Left	Thru	Right	Total	Left	Thru	Right	Total	Left	Thru	Right	Total		N	S	W	E
Totals	17	1498		1515		3172	25	3197					10		27	37	4749	40	8		38
Avg Hr	6	499		505		1057	8	1066					3		9	12	1583	13	3		13

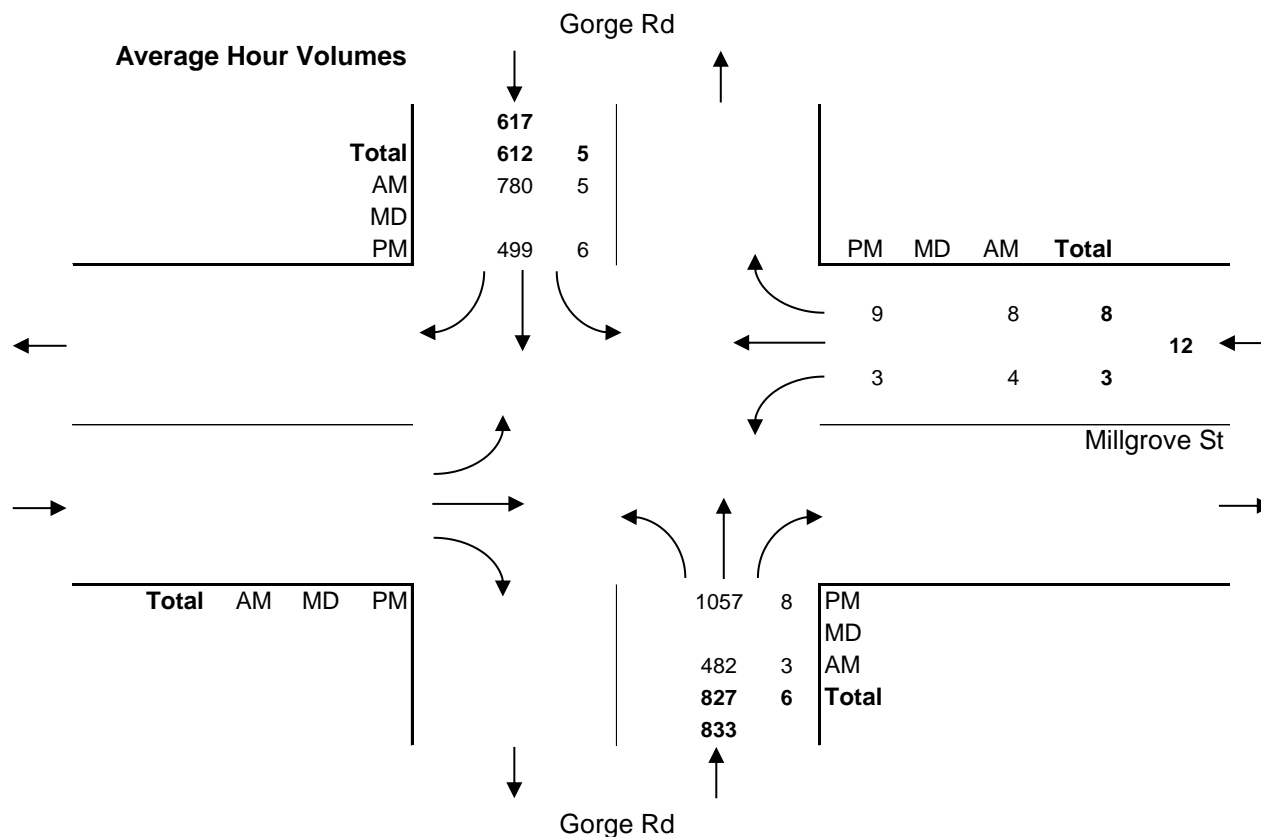

Major Route: Gorge Road
Minor Route: Millgrove Street
Municipality: Saanich
Filename: Gorge Rd @ Millgrove St-Apr 2, 2019.xlsx
Location #: TIN001042
Count ID: 2019013
Date: April 2, 2019
Day-of-week: Tuesday

East/West Route: Millgrove Street
Intersection Type: 4-leg
Signalized?: Yes
Weather: Overcast and dry

Vehicle Classifications: Vehicles and Peds
 Bikes

This data is for Bikes

Shift	Start	End	Duration
AM	7:30	9:30	2.00
MD			
PM	15:30	18:30	3.00
Total	7:30	18:30	5.00

Notes: 24-hour clock used for reporting (15-minute increments)
 North Approach - southbound vehicles approaching intersection from the north
 15x4 - 15 min volume (from maximum 15 minute period of movement/approach in peak hour period [*]) x 4
 Pedestrians - N indicates pedestrians crossing north approach (east/west)

Comments:

Survey Data
Bikes

Gorge Road @ Millgrove Street
Tuesday, April 2, 2019

Time Period Begins	Gorge Rd				Gorge Rd				WEST Approach				Millgrove St				Total Volume		Obs PL	N	S	W	E
	NORTH Approach				SOUTH Approach				Left	Thru	Right	Total	Left	Thru	Right	Total	15-min	Hour					
7:30	0	3	0	3	0	1	0	1	0	0	0	0	0	0	0	0	0	4		0	0	0	0
7:45	0	0	0	0	0	3	0	3	0	0	0	0	0	0	0	0	0	3	*	0	0	0	0
8:00	0	1	0	1	0	3	0	3	0	0	0	0	0	0	0	0	0	4	*	0	0	0	0
8:15	0	0	0	0	0	1	0	1	0	0	0	0	0	0	0	0	0	1	12*	0	0	0	0
8:30	0	5	0	5	0	1	0	1	0	0	0	0	0	0	0	0	0	6	14+	0	0	0	0
8:45	0	2	0	2	0	0	0	0	0	0	0	0	0	0	0	0	0	2	13	0	0	0	0
9:00	0	1	0	1	0	0	0	0	0	0	0	0	0	0	0	0	0	1	10	0	0	0	0
9:15	0	0	0	0	0	1	0	1	0	0	0	0	0	0	0	0	0	1	10	0	0	0	0
n/a																							
n/a																							
n/a																							
n/a																							
n/a																							
n/a																							
n/a																							
n/a																							
n/a																							
n/a																							
n/a																							
n/a																							
n/a																							
n/a																							
Total	0	12	0	12	0	10	0	10	0	0	0	0	0	0	0	0	0	22		0	0	0	0

n/a																							
n/a																							
n/a																							
n/a																							
n/a																							
n/a																							
n/a																							
n/a																							
n/a																							
n/a																							
n/a																							
n/a																							
n/a																							
n/a																							
n/a																							
n/a																							
n/a																							
n/a																							
n/a																							
n/a																							
Total																							

15:30	0	0	0	0	0	5	0	5	0	0	0	0	0	0	0	0	5			0	0	0	0
15:45	0	1	0	1	0	0	0	0	0	0	0	0	0	0	1	1	2			0	0	0	0
16:00	0	1	0	1	0	2	0	2	0	0	0	0	0	0	0	0	3			0	0	0	0
16:15	0	1	0	1	0	3	0	3	0	0	0	0	0	0	0	0	4	14+		0	0	0	0
16:30	0	2	0	2	0	2	0	2	0	0	0	0	0	0	0	0	4	13*		0	0	0	0
16:45	0	2	0	2	0	1	0	1	0	0	0	0	0	0	0	0	3	14*		0	0	0	0
17:00	0	0	0	0	0	4	0	4	0	0	0	0	0	0	0	0	4	15*		0	0	0	0
17:15	0	1	0	1	0	0	0	0	0	0	0	0	0	1	1	2	13			0	0	0	0
17:30	0	0	0	0	0	2	0	2	0	0	0	0	0	0	0	0	2	11		0	0	0	0
17:45	0	1	0	1	0	1	0	1	0	0	0	0	0	0	0	0	2	10		0	0	0	0
18:00	0	0	0	0	0	1	0	1	0	0	0	0	0	0	0	0	1	7		0	0	0	0
18:15	0	1	0	1	0	3	0	3	0	0	0	0	0	0	0	0	4	9		0	0	0	0
n/a																							
n/a																							
n/a																							
n/a																							
n/a																							
n/a																							
n/a																							
n/a																							
n/a																							
n/a																							
n/a																							
n/a																							
n/a																							
n/a																							
Total	0	10	0	10	0	24	0	24	0	0	0	0	0	0	0	2	2	36		0	0	0	0

Time Period Begins	Gorge Rd NORTH Approach				Gorge Rd SOUTH Approach				WEST Approach				EAST Approach				Total Volume		Knots	Conflict				
	Left	Thru	Right	Total	Left	Thru	Right	Total	Left	Thru	Right	Total	Left	Thru	Right	Total	15-min	Hour		N	S	W	E	15 min
7:30	0	3	0	3	0	1	0	1	0	0	0	0	0	0	0	0	4		0	0	0	0	3	
7:45	0	0	0	0	0	3	0	3	0	0	0	0	0	0	0	0	3	*	0	0	0	0	3	
8:00	0	1	0	1	0	3	0	3	0	0	0	0	0	0	0	0	4	*	0	0	0	0	3	
8:15	0	0	0	0	0	1	0	1	0	0	0	0	0	0	0	0	1	12*	0	0	0	0	1	10
8:30	0	5	0	5	0	1	0	1	0	0	0	0	0	0	0	0	6	14+	0	0	0	0	5	12
8:45	0	2	0	2	0	0	0	0	0	0	0	0	0	0	0	0	2	13	0	0	0	0	2	11
9:00	0	1	0	1	0	0	0	0	0	0	0	0	0	0	0	0	1	10	0	0	0	0	1	9
9:15	0	0	0	0	0	1	0	1	0	0	0	0	0	0	0	0	1	10	0	0	0	0	1	9
n/a																								
n/a																								
n/a																								
n/a																								
n/a																								
n/a																								
n/a																								
n/a																								
n/a																								
n/a																								
n/a																								
n/a																								
n/a																								

Total	0	12	0	12	0	10	0	10	0	0	0	0	0	0	0	0	0	22		0	0	0	0	12
Avg Hr	0	6	0	6	0	5	0	5	0	0	0	0	0	0	0	0	0	11		0	0	0	0	

Peak hour of the intersection

Pk Hr	0	6	0	6	0	8	0	8	0	0	0	0	0	0	0	0	0	14*		0	0	0	0	8
15x4	0	20	0	20	0	12	0	12	0	0	0	0	0	0	0	0	0	24+		0	0	0	0	20
PHF	n/a	0.30	n/a	0.30	n/a	0.67	n/a	0.67	n/a	n/a	n/a	n/a	n/a	n/a	n/a	n/a	n/a	0.58		n/a	n/a	n/a	n/a	0.40

Peak hour of conflicting volumes for the intersection

Pk Hr	0	6	0	6	0	8	0	8	0	0	0	0	0	0	0	0	0	14*		0	0	0	0	8
15x4	0	20	0	20	0	12	0	12	0	0	0	0	0	0	0	0	0	24+		0	0	0	0	20
PHF	n/a	0.30	n/a	0.30	n/a	0.67	n/a	0.67	n/a	n/a	n/a	n/a	n/a	n/a	n/a	n/a	n/a	0.58		n/a	n/a	n/a	n/a	0.40

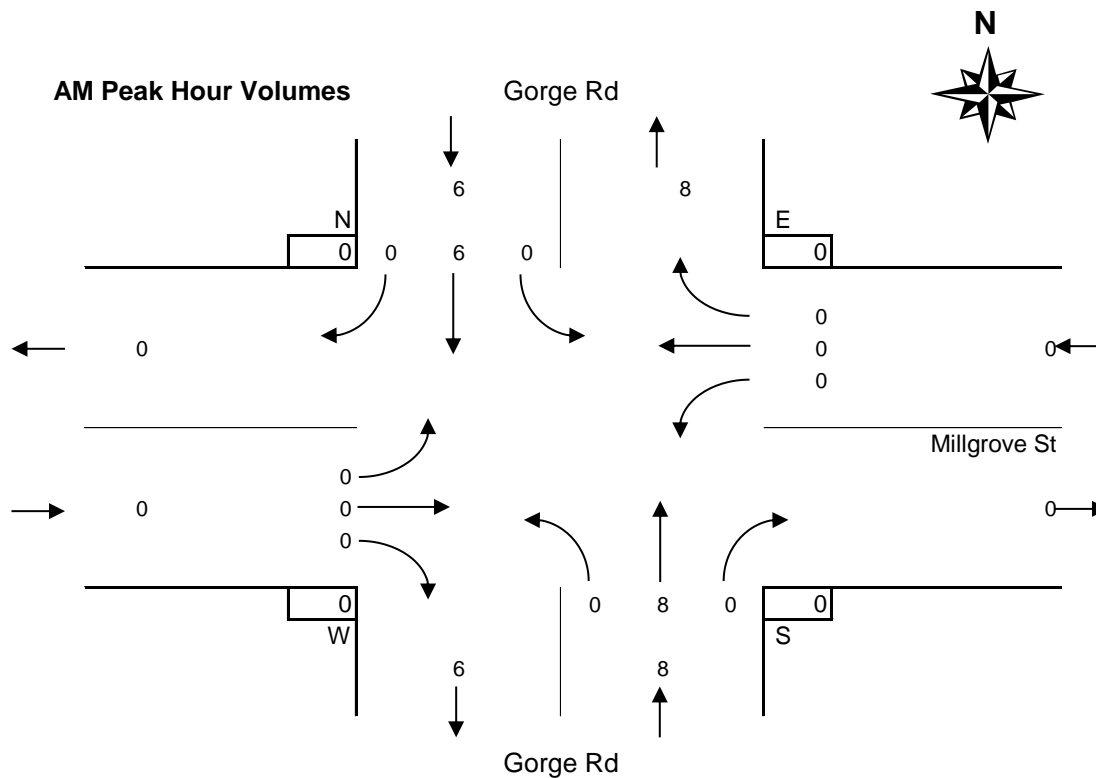

Time Period Begins	Gorge Rd NORTH Approach				Gorge Rd SOUTH Approach				WEST Approach				EAST Approach				Total Volume		Total PHF	Conflict				
	Left	Thru	Right	Total	Left	Thru	Right	Total	Left	Thru	Right	Total	Left	Thru	Right	Total	15-min	Hour		N	S	W	E	15 min
n/a																								
n/a																								
n/a																								
n/a																								
n/a																								
n/a																								
n/a																								
n/a																								
n/a																								
n/a																								
n/a																								
n/a																								
n/a																								
n/a																								

Total																									
Avg Hr																									

Peak hour of the intersection

Pk Hr																									
15x4																									
PHF																									

Peak hour of conflicting volumes for the intersection

Pk Hr																									
15x4																									
PHF																									

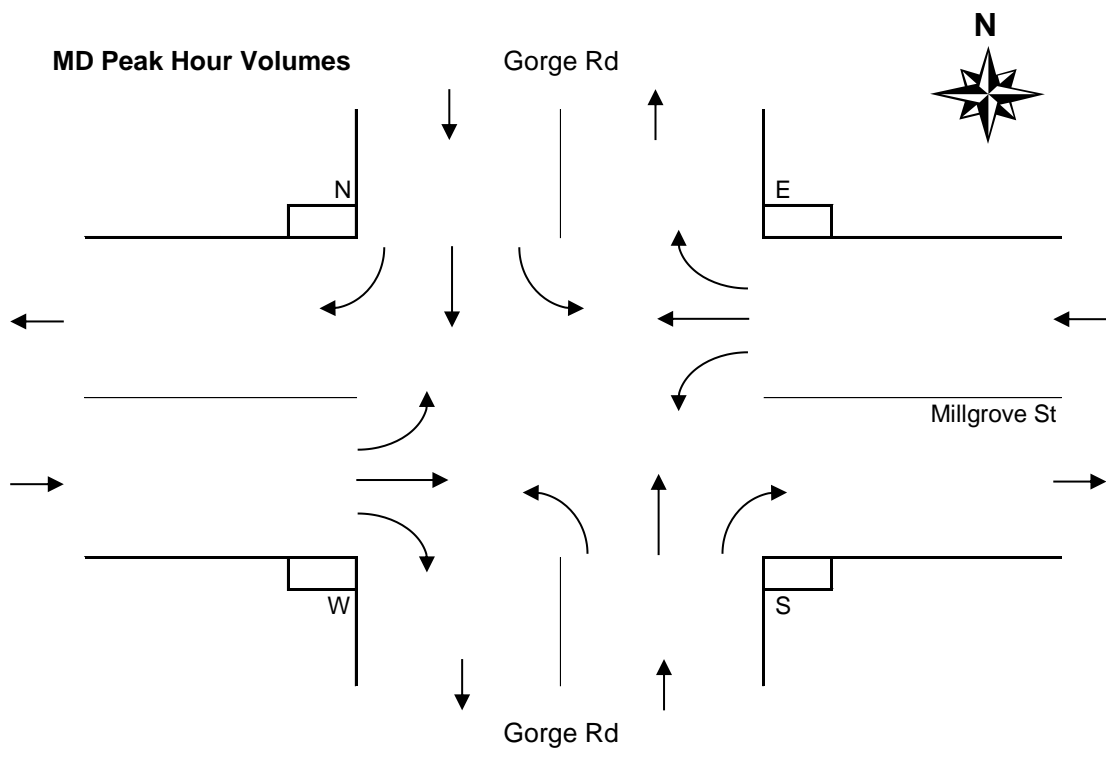

PM Peak Period
Bikes

Gorge Road @ Millgrove Street
Tuesday, April 2, 2019

Time Period Begins	Gorge Rd NORTH Approach				Gorge Rd SOUTH Approach				WEST Approach				MILLGROVE ST EAST Approach				Total Volume		Speed	Conflict				
	Left	Thru	Right	Total	Left	Thru	Right	Total	Left	Thru	Right	Total	Left	Thru	Right	Total	15-min	Hour		N	S	W	E	15 min
15:30	0	0	0	0	0	5	0	5	0	0	0	0	0	0	0	0	5		0	0	0	0	5	
15:45	0	1	0	1	0	0	0	0	0	0	0	0	0	0	1	1	2		0	0	0	0	2	
16:00	0	1	0	1	0	2	0	2	0	0	0	0	0	0	0	0	3		0	0	0	0	2	
16:15	0	1	0	1	0	3	0	3	0	0	0	0	0	0	0	0	4	14+	0	0	0	0	3	12
16:30	0	2	0	2	0	2	0	2	0	0	0	0	0	0	0	0	4	13*	0	0	0	0	2	9
16:45	0	2	0	2	0	1	0	1	0	0	0	0	0	0	0	0	3	14*	0	0	0	0	2	9
17:00	0	0	0	0	0	4	0	4	0	0	0	0	0	0	0	0	4	15*	0	0	0	0	4	11
17:15	0	1	0	1	0	0	0	0	0	0	0	0	0	0	1	1	2	13	0	0	0	0	2	10
17:30	0	0	0	0	0	2	0	2	0	0	0	0	0	0	0	0	2	11	0	0	0	0	2	10
17:45	0	1	0	1	0	1	0	1	0	0	0	0	0	0	0	0	2	10	0	0	0	0	1	9
18:00	0	0	0	0	0	1	0	1	0	0	0	0	0	0	0	0	1	7	0	0	0	0	1	6
18:15	0	1	0	1	0	3	0	3	0	0	0	0	0	0	0	0	4	9	0	0	0	0	3	7
n/a																								
n/a																								
n/a																								
n/a																								
n/a																								
n/a																								
n/a																								
n/a																								
n/a																								
n/a																								

Total	0	10	0	10	0	24	0	24	0	0	0	0	0	0	2	2	36		0	0	0	0		26
Avg Hr	0	3	0	3	0	8	0	8	0	0	0	0	0	0	1	1	12		0	0	0	0		

Peak hour of the intersection

Pk Hr	0	5	0	5	0	10	0	10	0	0	0	0	0	0	0	0	15+		0	0	0	0		10
15x4	0	8	0	8	0	16	0	16	0	0	0	0	0	0	0	0	16+		0	0	0	0		16
PHF	n/a	0.63	n/a	0.63	n/a	0.63	n/a	0.63	n/a	n/a	n/a	n/a	n/a	n/a	n/a	n/a	0.94		n/a	n/a	n/a	n/a		0.63

Peak hour of conflicting volumes for the intersection

Pk Hr	0	3	0	3	0	10	0	10	0	0	0	0	0	0	1	1	14+		0	0	0	0		11
15x4	0	4	0	4	0	20	0	20	0	0	0	0	0	0	4	4	20+		0	0	0	0		24
PHF	n/a	0.75	n/a	0.75	n/a	0.50	n/a	0.50	n/a	n/a	n/a	n/a	n/a	n/a	0.25	0.25	0.70		n/a	n/a	n/a	n/a		0.46

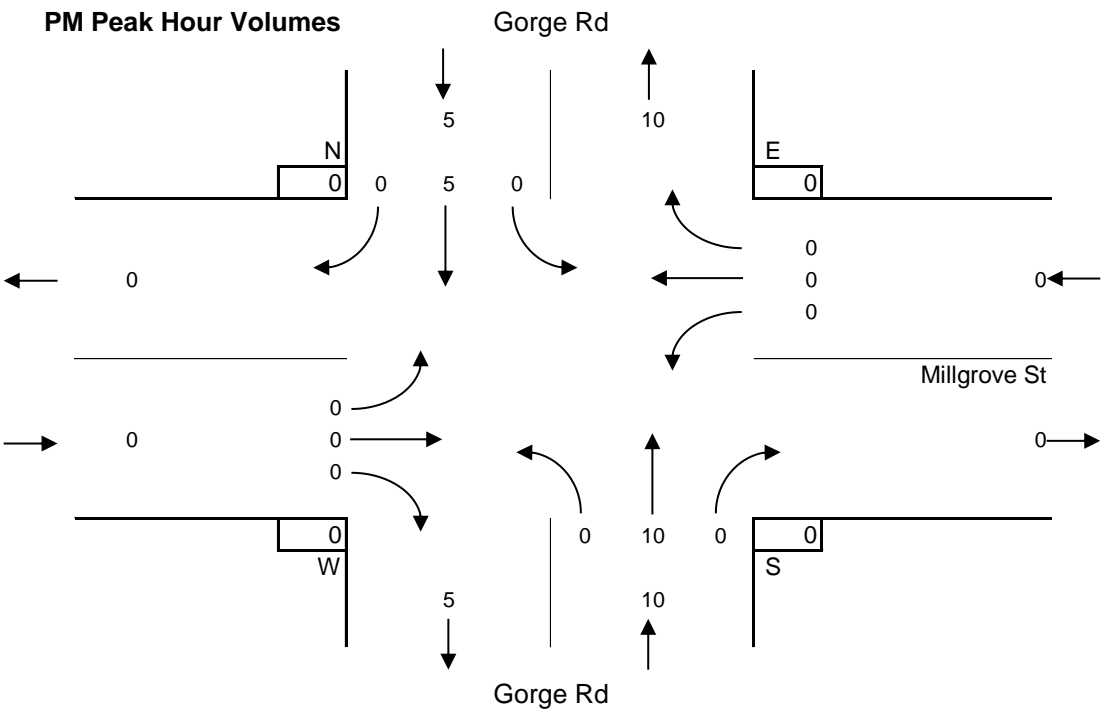

Entire Survey Period

5 Hours

	Gorge Rd				Gorge Rd				WEST Approach				Millgrove St				Total Volume				
	NORTH Approach				SOUTH Approach								EAST Approach					N S W E			
	Left	Thru	Right	Total	Left	Thru	Right	Total	Left	Thru	Right	Total	Left	Thru	Right	Total					
Total	0	22	0	22	0	34	0	34	0	0	0	0	0	0	2	2	58	0	0	0	0
Avg Hr	0	4	0	4	0	7	0	7	0	0	0	0	0	0	0	0	12	0	0	0	0

AM Peak Period

2 Hours

	Gorge Rd				Gorge Rd				WEST Approach				Millgrove St				Total Volume				
	NORTH Approach				SOUTH Approach								EAST Approach					N S W E			
	Left	Thru	Right	Total	Left	Thru	Right	Total	Left	Thru	Right	Total	Left	Thru	Right	Total					
Totals	0	12	0	12	0	10	0	10	0	0	0	0	0	0	0	0	22	0	0	0	0
Avg Hr	0	6	0	6	0	5	0	5	0	0	0	0	0	0	0	0	11	0	0	0	0

MD Peak Period

Hours

	Gorge Rd				Gorge Rd				WEST Approach				Millgrove St				Total Volume				
	NORTH Approach				SOUTH Approach								EAST Approach					N S W E			
	Left	Thru	Right	Total	Left	Thru	Right	Total	Left	Thru	Right	Total	Left	Thru	Right	Total					
Total																					
Avg Hr																					

PM Peak Period

3 Hours

	Gorge Rd				Gorge Rd				WEST Approach				Millgrove St				Total Volume				
	NORTH Approach				SOUTH Approach								EAST Approach					N S W E			
	Left	Thru	Right	Total	Left	Thru	Right	Total	Left	Thru	Right	Total	Left	Thru	Right	Total					
Totals	0	10	0	10	0	24	0	24	0	0	0	0	0	0	2	2	36	0	0	0	0
Avg Hr	0	3	0	3	0	8	0	8	0	0	0	0	0	0	1	1	12	0	0	0	0

